

## BLINDBOLTS

### The ultimate structural rivet

#### BBA RANGE

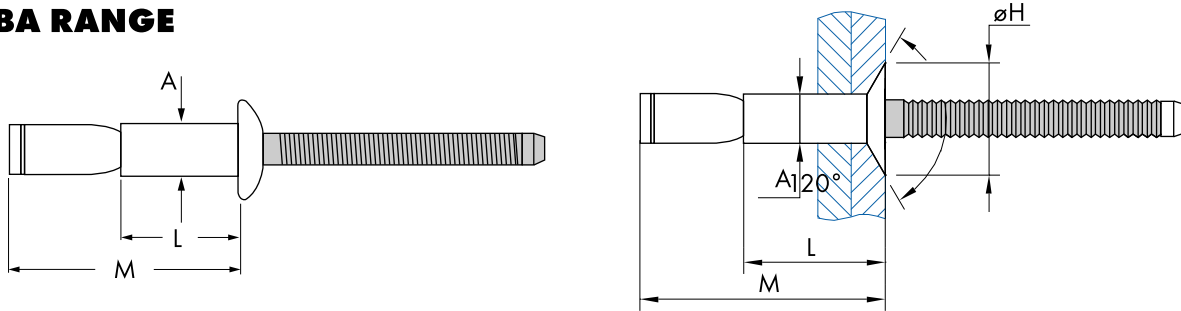

STEEL	DIA.	GRIP RANGE	L	A	M(MAX.)	H
BBA0817SD	1/4" 6.4mm	.080"-.375" 2.03-9.53	.550" 14.00	.256" 6.50	.993" 23.70	.500" 12.70
BBA0824SD	1/4" 6.4mm	.350"-.625" 2.03-15.87	.750" 19.05	.256" 6.50	1.29" 32.92	.500" 12.70
BBA0821SK	1/4" 6.4mm	.125"-.475" 3.17-12.07	.660"-.650" 16.76-16.51	.257"-.252" 6.53-6.40	1.063" 27.00	.395" 10.03
STAINLESS	DIA.	GRIP RANGE	L	A	M(MAX.)	H
BBA0817SSD	1/4" 6.4mm	.080"-.375" 2.03-9.53	.550" 14.00	.256" 6.50	.993" 23.70	.500" 12.70
BBA0824SSD	1/4" 6.4mm	.350"-.625" 2.03-15.87	.750" 19.05	.256" 6.50	1.29" 32.92	.500" 12.70
ALUMINIUM	DIA.	GRIP RANGE	L	A	M(MAX.)	H
BBA0817AAD	1/4" 6.4mm	.080"-.375" 2.03-9.53	.550" 14.00	.256" 6.50	.993" 23.70	.500" 12.70
BBA0824AAD	1/4" 6.4mm	.350"-.625" 2.03-15.87	.750" 19.05	.256" 6.50	1.29" 32.92	.500" 12.70

#### NOMINAL INSTALLED VALUES

	LBS			NEWTONS		
	Steel	Aluminium	Stainless	Steel	Aluminium	Stainless
SHEAR	2495	1305	2495	11100	5800	11100
TENSILE	2135	900	2135	9500	4000	9500
PIN RETENTION	440	200	440	1960	890	1960

Blind Bolt must be installed with special ridged nosepiece. Use of a regular nosepiece will not operate the locking system.

Blind Bolt must not be degreased before use.

#### Material and Finish

Material	Body	Mandrel	Body Finish	Mandrel Finish
Steel	AISI 1022/22B2	AISI 1035/35B2	Zinc and clear chromate	Zinc and yellow chromate
Aluminium	5056/3.3555	2014/3.1255	Natural	Natural
Stainless	AISI 302/1.4567	AISI 302/1.4567	Natural	Natural